



匯統國際股份有限公司

Huey Tung International Co., Ltd.

# 產品規格書

# Specification

[ Model : HT-4161 / 2012.12.13 version ]



**Cara Audio Corporation**

No.69, Lane 762, Dingzhong Road, Sanmin District, Kaohsiung City, Taiwan, ROC.

Tel: 886-7-310 5786 / Fax: 886-7-310 0783

E-mail: [carawang@hueytung.com.tw](mailto:carawang@hueytung.com.tw) / <http://www.hueytung.com.tw>

# 揚聲器製品規格書

## SPEAKER SPECIFICATION

**型號 Model Number: HT-4161 (70267)**

項目 Items		規格 Specification			
1	公称阻抗 Nominal Impedance	8Ω±15% at 200 Hz 1.0v			
2	最低共振周波数 Lowest Resonance Frequency	1800 Hz±20%Hz Without a baffle			
3	实效周波数带域 Effective Frequency Range	F0~20KHz -10dB			
4	出力音压 Output Sound Pressure Level	86dB±3dB 1W/1M at (3K,5K,7K,9K)Hz AVE.			
5	入力 Input	定格入力 Rated input 10 W	最大入力 Maximum input 15 W		
6	磁束密度 Flux Density	-----±10% GAUSS			
7	异常音试验电压 Buzz & Rattle Test	Must be normal at sine wave 6.32 V			
8	动作试验电压 Operation Test	Must be normal at program source 8.94 V			
9	极性 Polarity	/			
10	磁石尺寸/重量 Magnet Dimension/Weigh	Magnet:36*18*6 Y30 Sub Magnet:	22 G		
11	连续负荷试验 Life Test	PinkDin45573 noise 10 W 96 hours	After the Test, Speaker should be meet the Outside and item 7,8		
12	耐热试验 Heat Resistance	70°C±2°C 20%-25%RH 48Hours and then room temperature 1 hours			
13	耐湿试验 Humidity Resistance	40°C±2°C 90%-95%RH 48Hours and then room temperature 1 hours			
14	耐寒试验 Cold Resistance	/			
15	落下试验 Drop Test	1M 75°±2°			
16	绝缘耐压试验 Insulation Resistance	Or more 1MΩ 以上			
17	周波数特性 Frequency Response Curve	参照附图 On Other Drawing			
18	失真率 Distortion	MAX			
19	各部 材质	Cone Paper	Black Mylar		
		Voice Coil	/		
		Cap	/		
20	总重量 Total Weight	/			
		Size:60*45 試作發行: 2010.08.16	Approve: Arthur	Check: Tang	Design: LIU

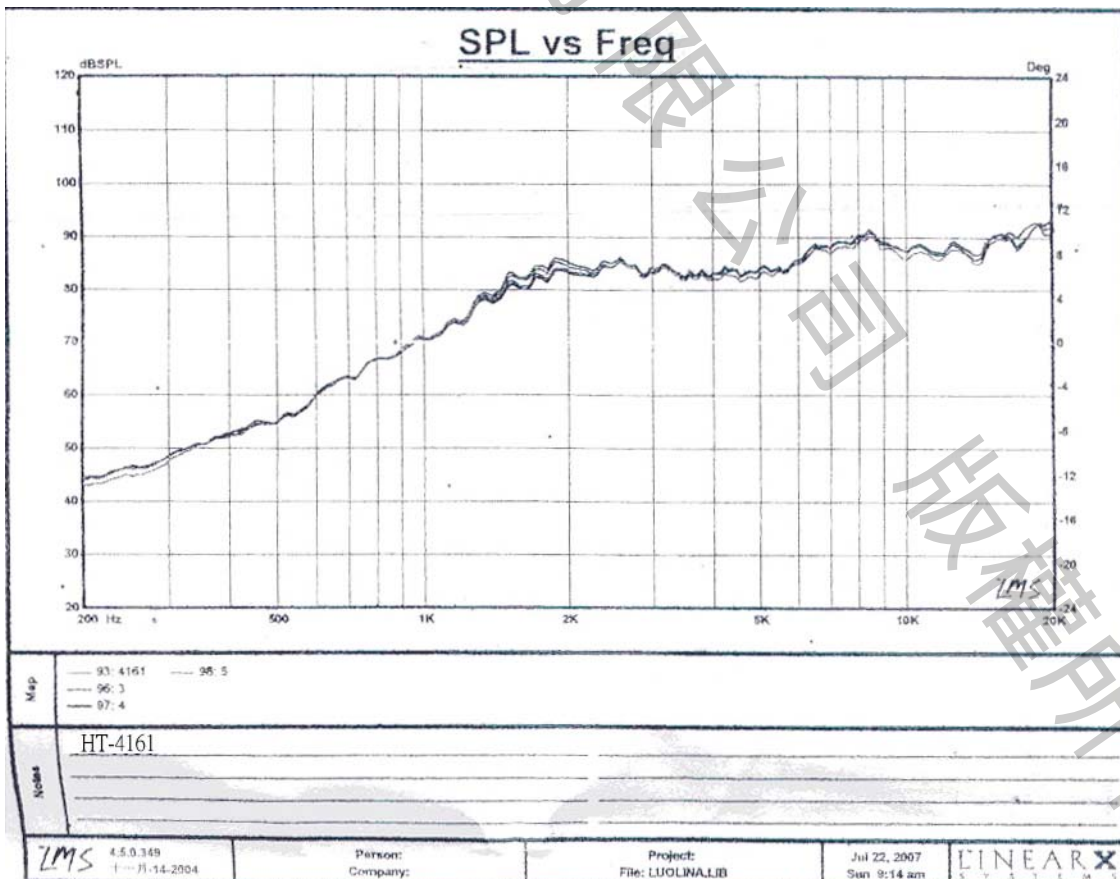
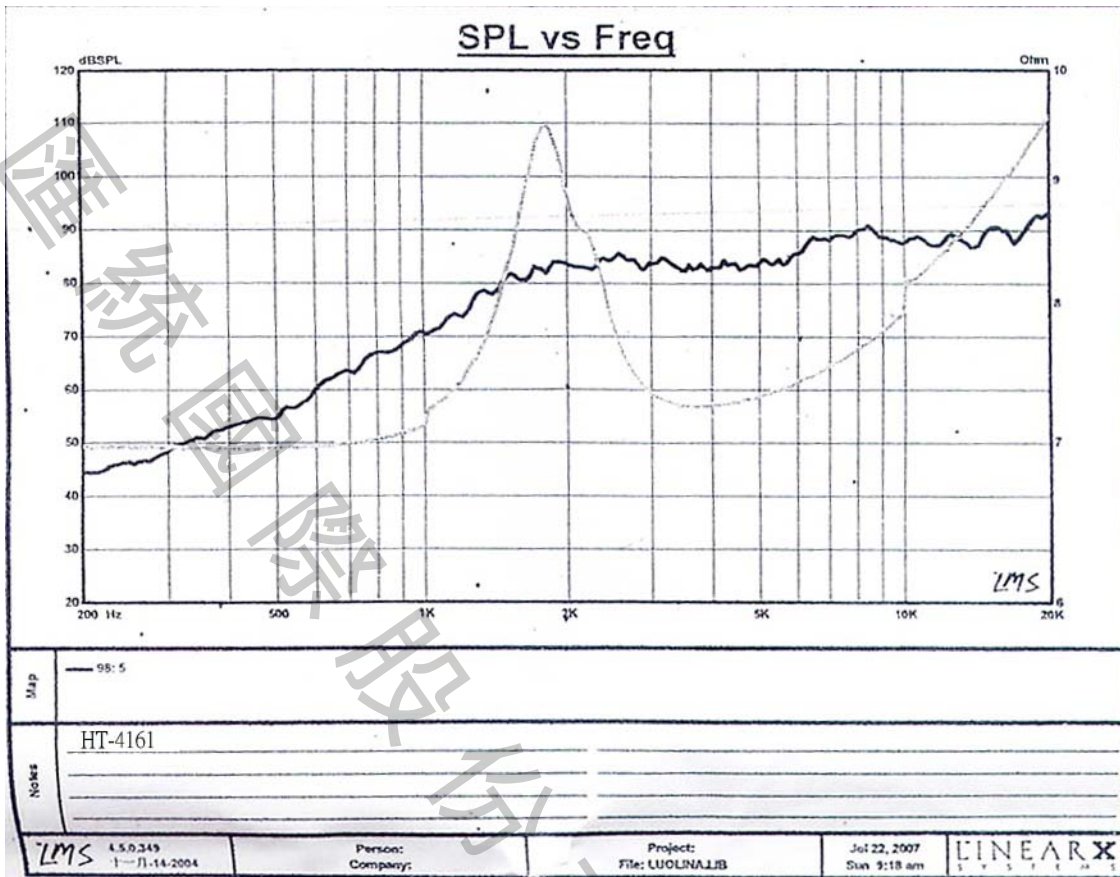

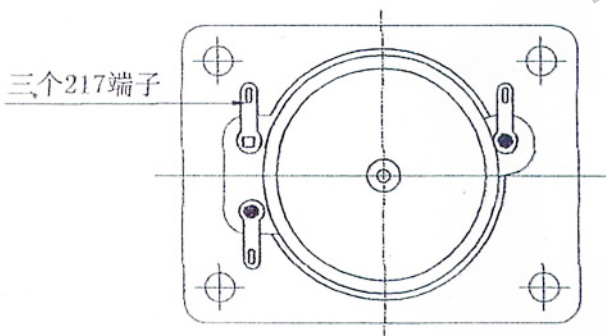
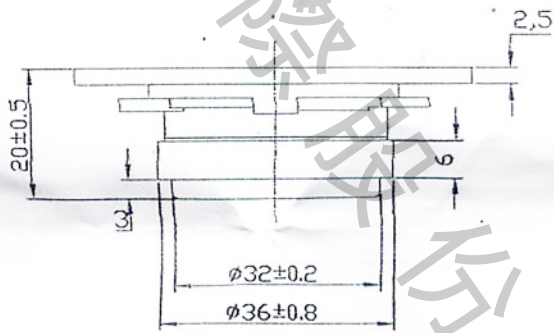
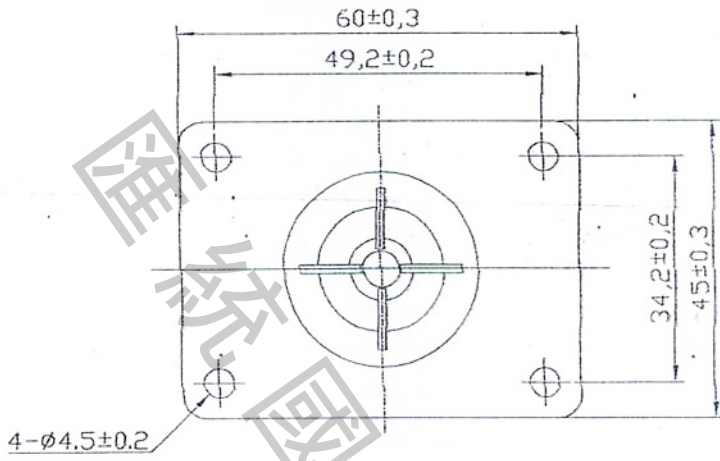

Toerance:  $\pm 0.5$

Unit:mm